

# Pacific52™ Thermal Recessed Frame

## Specifier & Builder guide for the Pacific52™ Thermal Recessed Frame

Aligning the thermal break of the window and door frames with the thermal envelope of the building enhances performance while also creating a clean contemporary aesthetic.

Powered by



Learn more:



# Pacific52™ Thermal

Our Pacific52™ system is the perfect solution if you're looking for a more comfortable, warmer, drier home. It uses a 'Polyamide Strip' to form a thermal barrier between the interior and exterior parts of the window or door frame. This barrier significantly reduces the transference of heat from the inside of the frame to the outside, thus restricting the amount of heat leaving (or the cold passing into) your house via your window system. As a result, less energy is required to maintain a steady temperature.

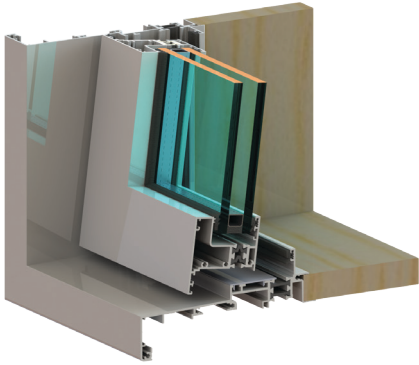

Figure 1: Polyamide strip Thermal Break isolates the inside of the frame from the outside, greatly reducing thermal loss.

# Recessed Frame - improving on great

Traditional window frames, and consequently the thermal break within the frame, have been designed and installed in such a way that, more often than not, they sit ahead or outside the wall of the building, exposing the frame to colder external temperatures.

A Recessed Frame on the other hand aligns all the insulation elements – the wall, window frame and glazing unit – by positioning the window frame in line with the actual wall structure. The thermal break and inner part of the frame are then sealed off from any circulating cold air with expanding foam, protecting them from external temperatures and minimising thermal loss via the frame.

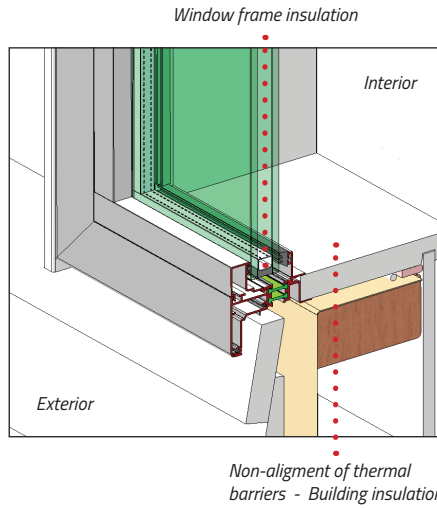

Figure 2: Traditional window position – the window sits ahead of or outside the wall of the building, allowing the cold air to circulate around the window and door frames.

\*For clarity purposes, Support Bar and Drainage Holes not shown in the figure above.

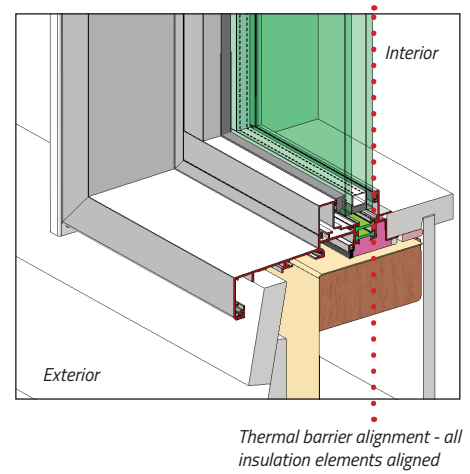

Figure 3: Recessing the window or door frame into the building and aligning all of the insulation elements increases the efficiency and performance of the building's thermal envelope.

\*For clarity purposes, Support Bar and Drainage Holes not shown in the figure above.



# Benefits

## Increased energy efficiency

Aligning all of the insulation elements – wall, window frame, glazing – and sealing off the thermal break and inner part of the frame with expanding foam, prevents cold air from circulating around the window or door frames, thereby improving the thermal performance and energy efficiency of the whole system. In practical terms, this means less chance of condensation forming whilst also making it easier to control the internal temperature of the home.

## Triple glazing

The standard 52mm system can accommodate triple glazing units; stepping up to the 60mm fixed window system allows for more expansive and higher performing triple glazing options.

## Dual colour

Choose different colours for the interior and exterior portions of your recessed window or door frame.

## Clean, contemporary lines

The joinery perimeter lines up with the exterior of the building, while the body of the window is recessed, creating a beautiful depth visually which can really compliment any project but works particularly well with strong monolithic forms.



# Installation

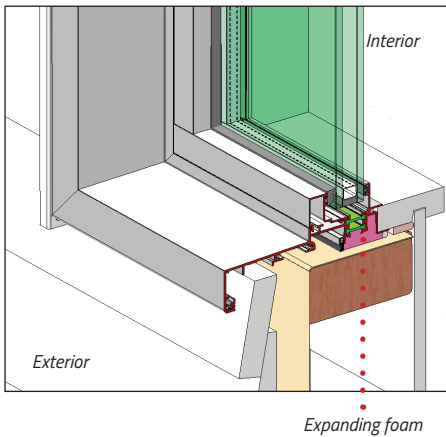

Figure 4: Expanding foam is used to fill the gap between the reveal and the frame, protecting the thermal break from cold air.

\*For clarity purposes, Support Bar and Drainage Holes not shown in the figure above.

## Foam injection

In order to protect the thermal break and the interior portion of the aluminium frame from any cooler air circulating between the cladding and the frame of the building, the cavity between the reveal and the frame is filled with an expanding foam on all four sides. The foam protects the back half of the aluminium frame and helps ensure that any thermal performance gains are realised.

## The ease of E2/AS1

Our recessed window:

- is compliant with all typical E2/AS1 installation details
- can be used with most proprietary claddings while still maintaining the insulating line of the building, i.e. the recessed frame flexibly interfaces with the chosen cladding system whilst maintaining thermal barrier alignment
- requires no extra parts or custom-made flashings to install the window thereby reducing time, cost and risk
- has no special installation requirements, meaning you get reliable installation every time

Performance up to and exceeding  
Extra High wind zone rating.

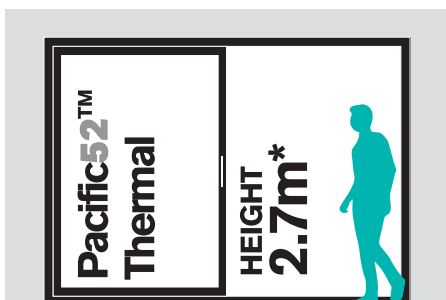

\*Higher spans are possible. Please contact your local fabricator for more information.



# Increased performance

One of the best ways to illustrate the difference in performance between a recessed frame and a non-recessed frame is to measure and compare the temperature of both sets of frames under controlled conditions\* in which the interior (20°C) and exterior (0°C) temperatures are replicated.

Under these conditions the temperature of the interior of the Recessed Frame drops to a minimum of 13°C (see Figure 5), while the interior metal in the traditional frame drops to a minimum of 3°C.

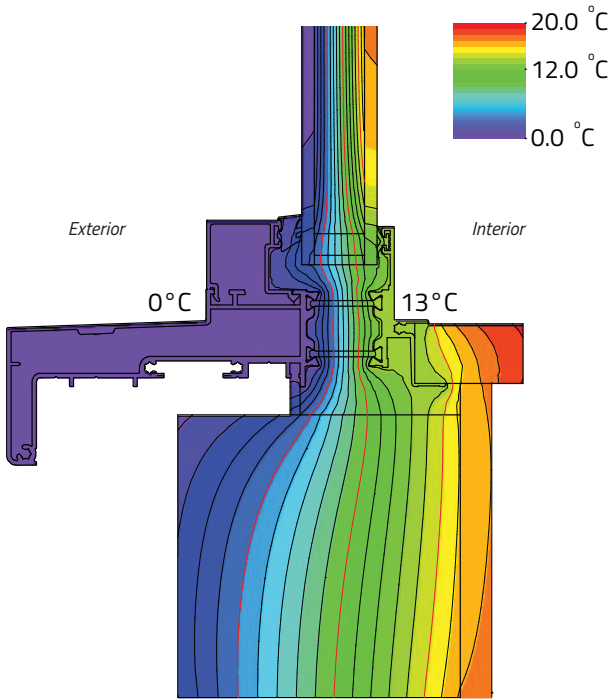

Figure 5: Under controlled conditions (interior 20°C, exterior 0°C) the temperature of the Recessed Frame drops to a minimum of 13°C. A traditional frame under the exact same controlled conditions drops to a minimum of 3°C.

Learn more:



## Sharing your vision

[altus.co.nz](http://altus.co.nz)

Technical Enquiry: 0800 925 500  
Email: [technical@altus.co.nz](mailto:technical@altus.co.nz)

General Enquiry: 0800 4 ALTUS (425 887)  
Email: [altus.enquiry@altus.co.nz](mailto:altus.enquiry@altus.co.nz)

In practical terms the Recessed Frame's higher minimum temperature means far less energy is required to regulate and maintain the interior temperature versus that needed for a traditional frame. Minimum temperatures will, of course, vary across the country.

This illustrates the key benefit of the Recessed Frame which is to fully realise the modelled thermal performance of a window or door unit.

\*Model calculations based on 1m x 1m P60 recessed fixed window and following ISO 13788 (fRsi boundary conditions), ISO 10077 1&2 (U value), ISO 10211 (Installation)

### A note on condensation

Although moisture forming on windows is often the first visible sign of condensation, there are many factors involved – ventilation, orientation, solar heat gain, thermal mass and indoor air quality to name a few. Because of this Altus encourages a holistic approach to designing buildings – a Recessed Frame can certainly lower the chances of condensation occurring thanks to higher minimum temperatures relative to the Dew Point (the point at which condensation forms on the glass surface, typically 11°C in a room with a temperature of 21°C and humidity of 55%) – but all the other factors mentioned also have a role to play.

The Altus Recessed Frame is a simple and easy solution - easy for the designer, easy for the builder, and they are available nationwide through our exclusive fabricator network.

Altus is also available to help with as much or as little detail as needed.

### The Recessed Frame is available in the following products:

- Windows – awning and casement
- Hinged and French doors
- Bifold doors
- Euroslider™ and Eurostacker™ doors

Your Local Fabricator:

Powered by

